

# LINEA FLEXO, KIUDO E COMPO GUIDA ALLA LETTURA FLEXO, KIUDO AND COMPO LINES: GUIDE TO READING

**LINEA DI PRODOTTO**  
Product Line

**FAMIGLIA DI PRODOTTO**  
Product Family

**COMP** ELEMENTI DI BASE SERIE NYLON - NYLON LEVELLING LINE

**SERIE**  
Series

**EL** Piede Fisso in PE Rivestito da Lamiera Zincata  
PE Fixed Foot, Iron Sheet Plated

**FOTO PRODOTTO**  
Product Photo

**DISEGNO TECNICO PRODOTTO**  
Technical Drawing Product

**COD. CODICE ARTICOLO**  
Item Code

COD.	A	M	B	H	Carico Max Statico Maximum Load daN	PZ
A3EL1	20	06MA	13	7	100	24
A3EL2	25	08MA	20	10	120	24
A3EL3	25	10MA	20	10	120	24
A3EL4	30	08MA	20	11,5	150	24
A3EL5	30	10MA	20	11,5	150	24
A3EL6	40	08MA	25	13,5	180	24
A3EL7	40	10MA	25	13,5	180	24
A3EL8	50	10MA	30	15,5	200	24
A3EL9	50	12MA	35	15,5	200	24

**NUMERO DI PZ IN UNA CONFEZIONE**  
Packing pcs

**INFORMAZIONI TECNICHE SUL PRODOTTO**  
Technical Information about the Product

**Caratteristiche**  
MATERIALE BASE: Polietilene nero rivestito da lamiera zincata  
MATERIALE STELO: Acciaio zincato  
TIPO STELO: Fisso  
PRESENTAZIONE PRODOTTO: Stelo solidale alla base  
CARATTERISTICHE SPECIFICHE: Livellamento in altezza agendo sulla base

**Product specification**  
BASE MATERIAL: Polyethylene, iron sheet plated  
SPINDLE MATERIAL: Zinc plated steel  
SPINDLE TYPE: Fixed  
PRODUCT PRESENTATION: Base assembled with the stud  
SPECIFIC FEATURES: Height leveling achievable by screwing down the base

## SIGNIFICATO DELLE SIGLE ED ABBREVIAZIONI ABBREVIATIONS AND ACRONYMS

### 1. MISURE DI LUNGHEZZA / MEASURES OF LENGTH

**mm** = millimetro / millimeter  
**cm** = centimetro / centimeter  
**MT o mt** = metro lineare / linear meter  
**mm²** = millimetro quadrato / square millimeter  
**cm²** = centimetro quadrato / square centimeter  
**cm³** = centimetro cubo / cubic centimeter  
**m² o mq** = metro quadrato / square meter  
**ø** = diametro / diameter

### 2. FILETTATURE / Threads

**MA - M** = filettatura metrica ISO passo M  
 ISO metric MA thread  
 “ = pollici / inches

### 3. MISURE DI PESO, FORZA, PRESSIONE e FREQUENZA MEASURES OF WEIGHT, FORCE, PRESSURE & FREQUENCY

**Kg** = chilogrammo / kilogram  
**N** = Newton / Newton (1 N=0,102 Kg)  
**Nm** = Newton Metro / Newton Meter  
**daN** = dekaNewton / dekaNewton (1 daN = 1,02 Kg)  
**Mpa** = Megapascal (1 Mpa = 1 N/mm² = 10 bar)  
**bar** (1 bar = 10N/cm²)  
**Hz** = Hertz / Hertz

### 4. GOMME e PLASTICHE / RUBBER and PLASTIC

• **SH** = durezza gomma espressa in gradi shore A  
 shore A rubber hardness  
 • **NR** = Gomma Naturale / Natural Rubber  
 (+ proprietà fisiche, abrasione, acidi ed alcali; - olii minerali, acqua, calore  
 (+ physical properties, abrasion, acids and alkali; - mineral oils, water, heat)  
 • **SBR** = Stirene Butadiene / Styrene-Butadiene  
 (+ proprietà fisiche, abrasione; - prodotti petroliferi, olii, calore  
 (+ physical properties, abrasion; - petroleum based fluids, oils, heat

• **NBR** = Nitrile Butadiene (antiolio) / Nitrile - Butadiene (oil resistant)  
 (++) olii + solventi aromatici ed alifatici, proprietà fisiche  
 (++) oils + aromatic and aliphatic solvents, physical properties)  
 • **CR** = Cloroprene (comunemente conosciuto come neoprene®)  
 Chloroprene (commonly known as Neoprene®)  
 (++) agenti atmosferici + olii, proprietà fisiche, calore, ritardante all  
 propagazione della fiamma  
 (++) weather conditions + oils, physical properties, heat, flame retardant

• **PU** = Poliuretano / Polyurethane  
 (++) abrasione + proprietà fisiche, olii; - acqua, alcali, acidi  
 (++) abrasion + physical properties, oils; - water, acids and alkali)

### MATERIALI TERMOPLASTICI / THERMOPLASTIC MATERIALS:

• **PA** = Poliammide (comunemente conosciuta come nylon)  
 polyamide (commonly known as nylon)  
 • **TPE** = Gomma Termoplastica / Thermoplastic Elastomer  
 • **PVC** = Cloruro di Polivinile / Polyvinil Chlorure  
 • **PTFE** = Politetrafluoro Etilene (comunemente conosciuto come Teflon)  
 Polytetrafluoro Ethylene (commonly known as eflon  
 • **PP** = Polipropilene / Polypropylene

### MATERIALI TERMOINDURENTI / THERMOSETTING MATERIALS:

• **PF** = Resina Fenolica (comunemente conosciuta come Bachelite)  
 Phenolic Resin (commonly known as Bachelite)

### 7. ABBREVIAZIONI GENERALI - General Abbreviations

**PZ / pcs** = pezzi / pieces  
**max** = massimo / maximum  
**min** = minimo / minimum  
**int.** = interasse fori / distance between holes  
**RT** = rotolo / coil (roll)

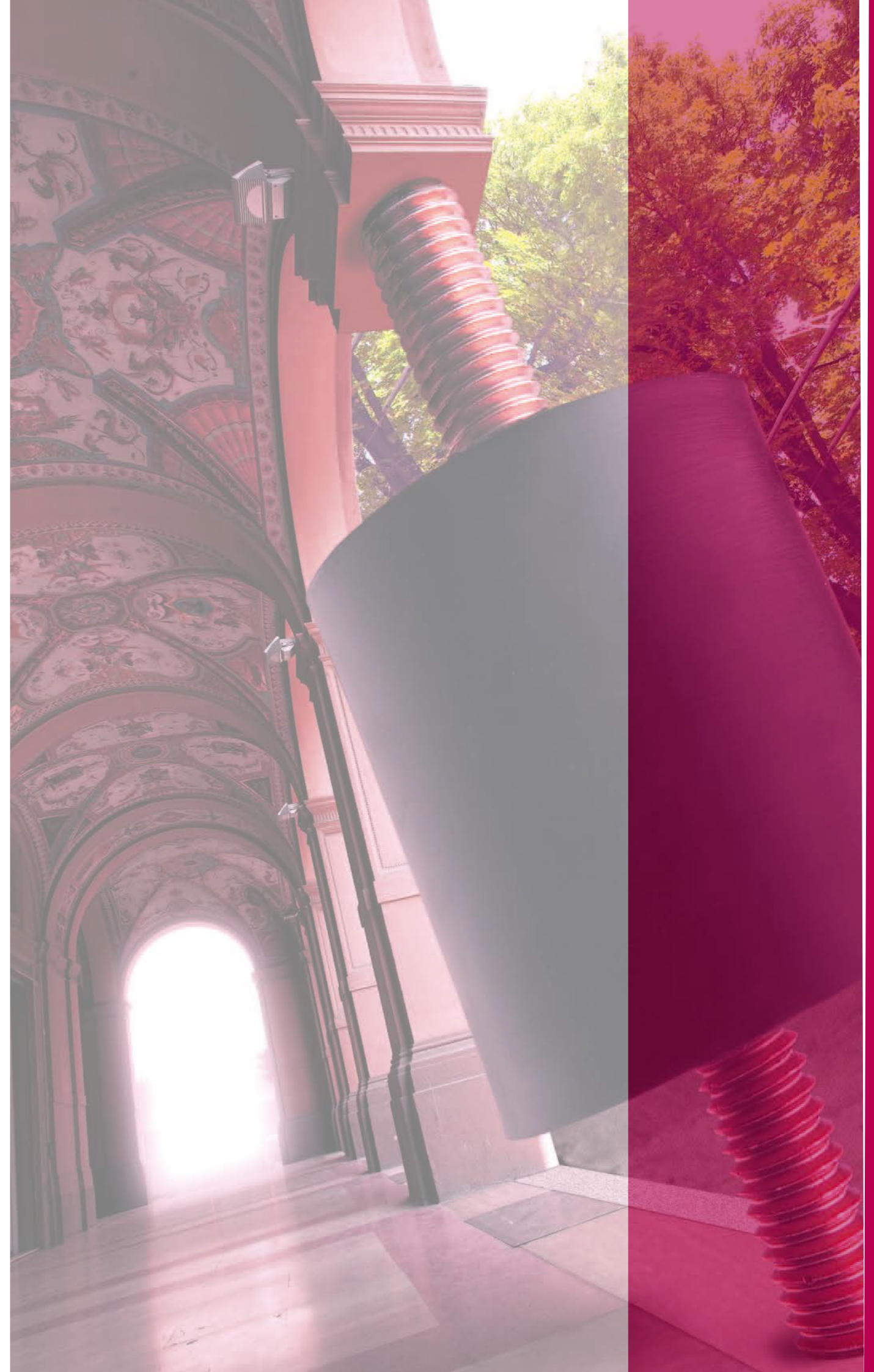

VIBRATION CONTROL LINE

# GETECH PUNTA AL SERVIZIO GETECH CARES ABOUT SERVICE

E nel tempo ha continuato a cercare soluzioni per supportare i propri clienti.  
And time after time it has always looked for helpful solutions for its customers' needs.



E' così che sono nate le sue linee di packaging: **pratiche, colorate, impilabili**, le scatole **FLEGO** aiutano a organizzare meglio il magazzino e il punto vendita, e a gestire più velocemente le spedizioni.

That's why we created our **FLEGO** boxes. **Handy, colourful, stockable**, they will help you in organizing your warehouse and your shop, and make your deliveries faster.



## ANTIVIBRANTI CILINDRICI - CYLINDRICAL MOUNTINGS



### MM

Antivibrante Cilindrico in Acciaio Zincato Maschio/Maschio  
Zinc Plated Double Male Cylindrical Mounting

COD.	A	B	M	E	Carico max a Compres. Max Compression Load daN	Carico max a Taglio Max Shear Load daN
A1MM1310	13	10	05MA	10	15	2
A1MM1510	15	10	04MA	10	15	2
A1MM1515	15	15	04MA	14	15	2
A1MM1515L	15	15	04MA	19	15	2
A1MM2010	20	10	06MA	16	36	3
A1MM2015	20	15	06MA	16	34	4
A1MM2020	20	20	06MA	16	34	2
A1MM2025	20	25	06MA	16	24	3
A1MM2030	20	30	06MA	16	24	5
A1MM2510	25	10	06MA	20	35	5
A1MM2515	25	15	06MA	18	35	5
A1MM2520/6	25	20	06MA	18	45	5
A1MM2520/8	25	20	08MA	20	45	5
A1MM2525	25	25	06MA	18	40	5
A1MM2530/6	25	30	06MA	18	34	3
A1MM2530/8	25	30	08MA	20	34	3
A1MM3015	30	15	08MA	23	42	9
A1MM3020-15	30	20	08MA	15	66	9
A1MM3020	30	20	08MA	23	66	9
A1MM3025	30	25	08MA	20	66	9
A1MM3030	30	30	08MA	20	61	7
A1MM3040	30	40	08MA	20	55	5
A1MM4020	40	20	08MA	23	63	12
A1MM4030/10	40	30	10MA	28	98	15
A1MM4030/8	40	30	08MA	23	98	15
A1MM4035	40	35	08MA	23	88	13
A1MM4040/10	40	40	10MA	28	107	13
A1MM4040/8	40	40	08MA	23	107	13
A1MM5020	50	20	10MA	28	168	21
A1MM5030	50	30	10MA	28	158	19
A1MM5040	50	40	10MA	28	143	17
A1MM5045	50	45	10MA	28	136	16
A1MM5050	50	50	10MA	28	133	13
A1MM6030/12	60	30	12MA	37	172	36
A1MM6040/12	60	40	12MA	37	169	28
A1MM6050/10	60	50	10MA	35	199	24
A1MM6050/12	60	50	12MA	37	199	24
A1MM6535	65	35	12MA	37	300	46
A1MM6550	65	50	12MA	37	230	23
A1MM7040/10	70	40	10MA	28	210	40
A1MM7050/10	70	50	10MA	28	230	55
A1MM7050/12	70	50	12MA	37	230	55
A1MM7525	75	25	12MA	37	382	89
A1MM7540	75	40	12MA	37	377	79
A1MM7550	75	50	12MA	37	372	69
A1MM10030	100	30	16MA	42	700	110
A1MM10040	100	40	16MA	42	685	99
A1MM10050	100	50	16MA	42	560	99
A1MM10055	100	55	16MA	42	635	79
A1MM10060	100	60	16MA	42	587	49

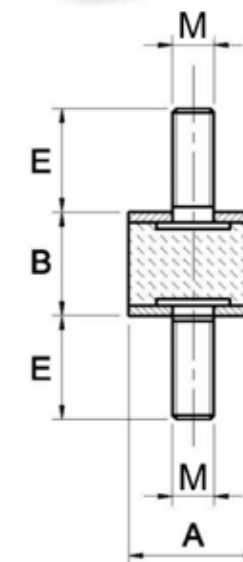

#### Caratteristiche

- MATERIALE CORPO:**  
Mescola Gomma NR/SBR
- DUREZZA STANDARD:**  
60 Shore A
- TOLLERANZA SULLA DUREZZA:**  
+/- 5 SH
- A RICHIESTA:**  
Differenti lunghezze della vite
- PARTE METALLICA E/O FISSAGGIO:**  
Vite e rondella zincate
- TIPO INSERTO STANDARD:**  
Vite pressata sulla rondella

#### Product specificatio

- MAIN PART MATERIAL:**  
NR/SBR rubber compound
- STANDARD HARDNESS:**  
60 Shore A
- HARDNESS TOLERANCE:**  
+/- 5 SH
- ON REQUEST:**  
Different screw lengths
- METALLIC PART:**  
Zinc plated screw and washer
- STANDARD THREAD:**  
Screw pressed on the washer

Misure e durezze differenti producibili su richiesta, rivolgersi all'ufficio commerciale. La quota "E" può essere soggetta a variazioni senza preavviso.  
Other sizes or hardness can be produced on demand, for information please contact our sales department. The "E" dimension can vary without giving notice.

**MMT**
**Antivibrante Cilindrico in Acciaio Zincato Maschio/Maschio (Gomma Tenera)**  
**Zinc Plated Double Male Cylindrical Mounting (Soft Type)**

COD.	A	B	M	E	Carico max a Compres.	Carico max a Taglio
					Max Compression Load daN	Max Shear Load daN
A1MMT2520	25	20	06MA	18	27	3,3
A1MMT3015	30	15	08MA	23	34	3,8
A1MMT3020	30	20	08MA	23	40	6
A1MMT3030	30	30	08MA	23	37	4,7
A1MMT4030	40	30	08MA	23	59	10
A1MMT4040	40	40	08MA	23	73	10
A1MMT5030	50	30	10MA	28	95	13
A1MMT5040-20	50	40	10MA	20	88	11
A1MMT5040	50	40	10MA	28	88	11

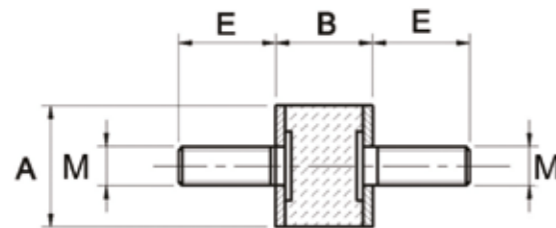
**Caratteristiche**

**MATERIALE CORPO:**  
Mescola gomma NR/SBR  
**DUREZZA STANDARD:**  
45 shore A  
**TOLLERANZA SULLA DUREZZA:**  
+/- 5 SH  
**A RICHIESTA:**  
Differenti lunghezze della vite  
**PARTE METALLICA E/O FISSAGGIO:**  
Vite e rondella zincate  
**TIPO INSERTO STANDARD:**  
Vite pressata sulla rondella  
**Product specificatio**  
**MAIN PART MATERIAL:**  
NR/SBR rubber compound  
**STANDARD HARDNESS:**  
45 shore A  
**HARDNESS TOLERANCE:**  
+/- 5 SH  
**ON REQUEST:**  
Different screw lengths  
**METALLIC PART:**  
Zinc plated screw and washer  
**STANDARD THREAD:**  
Screw pressed on the washer

**MMX**
**Antivibrante Cilindrico in Acciaio Inox AISI 304 Maschio/Maschio**  
**AISI 304 Stainless Steel Double Male Cylindrical Mounting**
**INOX**  
Stainless Steel

COD.	A	B	M	E	Carico max a Compres.	Carico max a Taglio
					Max Compression Load daN	Max Shear Load daN
A1MMX1515	15	15	04MA	14	15	2
A1MMX2015	20	15	06MA	16	34	4
A1MMX2520/6	25	20	06MA	18	45	5
A1MMX3015	30	15	08MA	12	42	9
A1MMX3030	30	30	08MA	20	61	7
A1MMX4030/8	40	30	08MA	23	98	15

Misure e durezza differenti producibili su richiesta, rivolgersi all'ufficio commerciale. La quota "E" può essere soggetta a variazioni senza preavviso.

Other sizes or hardness can be produced on demand, for information please contact our sales department. The "E" dimension can vary without giving notice.

**Caratteristiche**

**MATERIALE CORPO:**  
Mescola gomma NR/SBR  
**DUREZZA STANDARD:**  
60 shore A  
**TOLLERANZA SULLA DUREZZA:**  
+/- 5 SH  
**A RICHIESTA:**  
Differenti lunghezze della vite  
**PARTE METALLICA E/O FISSAGGIO:**  
Vite e rondella inox AISI 304  
**TIPO INSERTO STANDARD:**  
Vite pressata sulla rondella  
**Product specificatio**  
**MAIN PART MATERIAL:**  
NR/SBR rubber compound  
**STANDARD HARDNESS:**  
60 shore A  
**HARDNESS TOLERANCE:**  
+/- 5 SH  
**ON REQUEST:**  
Different screw lengths  
**METALLIC PART:**  
Stainless steel screw and washer AISI 304  
**STANDARD THREAD:**  
Screw pressed on the washer

**MF**
**Antivibrante Cilindrico in Acciaio Zincato Maschio/Femmina**  
**Zinc Plated Male/Female Cylindrical Mounting**

COD.	A	B	M	E	F	Carico max a Compres.	Carico max a Taglio
						Max Compression Load daN	Max Shear Load daN
A1MF1515	15	15	04MA	14	4	15	3
A1MF2015	20	15	06MA	16	6	34	3
A1MF2020	20	20	06MA	16	6	29	2
A1MF2025	20	25	06MA	16	6	19	2
A1MF2030	20	30	06MA	16	6	15	2
A1MF2515S	25	15	06MA	8	6	40	6
A1MF2515	25	15	06MA	18	6	40	6
A1MF2518	25	18	05MA	12	*	40	6
A1MF2520/6	25	20	06MA	18	6	45	5
A1MF2520/8	25	20	08MA	20	8	45	5
A1MF2525	25	25	06MA	18	6	40	4
A1MF2530	25	30	06MA	18	6	35	3
A1MF3015	30	15	08MA	18	8	58	10
A1MF3020	30	20	08MA	23	8	66	9
A1MF3020/14	30	20	08MA	14	8	66	9
A1MF3030	30	30	08MA	23	8	61	7
A1MF3040	30	40	08MA	23	8	54	5
A1MF4020	40	20	08MA	23	8	88	16
A1MF4030/10	40	30	10MA	28	10	98	15
A1MF4030/8	40	30	08MA	23	8	98	15
A1MF4035	40	35	08MA	23	8	88	13
A1MF4040/10	40	40	10MA	28	10	108	13
A1MF4040/8	40	40	08MA	23	8	108	13
A1MF5020	50	20	10MA	28	10	169	21
A1MF5030	50	30	10MA	28	10	159	20
A1MF5040	50	40	10MA	28	10	144	18
A1MF5050	50	50	10MA	28	10	134	14
A1MF6030/12	60	30	12MA	37	12	228	40
A1MF6035/10	60	35	10MA	28	10	228	40
A1MF6040/12	60	40	12MA	28	12	214	30
A1MF6050/10	60	50	10MA	35	10	200	24
A1MF6050/12	60	50	12MA	37	12	200	24
A1MF6535	65	35	12MA	37	12	300	46
A1MF6550	65	50	12MA	37	12	230	23
A1MF7050/12	70	50	12MA	37	12	280	38
A1MF7525	75	25	12MA	37	12	382	89
A1MF7540	75	40	12MA	37	12	378	78
A1MF7550	75	50	12MA	37	12	373	68
A1MF10030	100	30	16MA	42	16	720	110
A1MF10040	100	40	16MA	42	16	686	98
A1MF10050	100	50	16MA	42	16	660	98
A1MF10055	100	55	16MA	42	16	636	78
A1MF10060	100	60	16MA	42	16	586	48

\* inserto femmina 06MA x 8  
threaded blind hole 06MA x 8

**Caratteristiche**

**MATERIALE CORPO:**  
Mescola gomma NR/SBR  
**DUREZZA STANDARD:**  
60 shore A  
**TOLLERANZA SULLA DUREZZA:**  
+/- 5 SH  
**A RICHIESTA:**  
Differenti lunghezze della vite  
Inserto femmina passante  
**PARTE METALLICA E/O FISSAGGIO:**  
Rondella zincata  
**TIPO INSERTO STANDARD:**  
Vite zincata, inserto femmina cieco  
**Product specification**  
**MAIN PART MATERIAL:**  
NR/SBR rubber compound  
**STANDARD HARDNESS:**  
60 shore A  
**HARDNESS TOLERANCE:**  
+/- 5 SH  
**ON REQUEST:**  
Different screw lengths  
Threaded through-hole  
**METALLIC PART:**  
Zinc plated washer  
**STANDARD THREAD:**  
Zinc plated screw, threaded blind hole

Misure e durezza differenti producibili su richiesta, rivolgersi all'ufficio commerciale. La quota "E" ed "F" possono essere soggette a variazioni senza preavviso, ci riserviamo inoltre la facoltà di fornire antivibranti provvisti di inserto cieco o passante a seconda della disponibilità di parti metalliche.

Other sizes or hardness can be produced on demand, for information please contact our sales department. "E" and "F" dimensions can vary without giving notice. It is GeTech's discretion to supply antivibration mountings with threaded blind hole or with through hole depending on the metallic parts available at the moment.

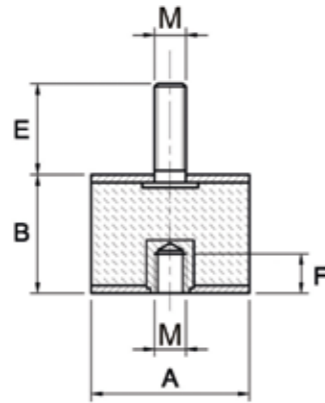
**MFT**
**Antivibrante Cilindrico in Acciaio Zincato Maschio/Femmina (Gomma Tenera)**  
*Zinc Plated Male/Female Cylindrical Mounting (Soft Type)*

COD.	A	B	M	E	F	Carico max a Compres. Max Compression Load daN	Carico max a Taglio Max Shear Load daN
A1MFT2025	20	25	06MA	16	6	11	1,3
A1MFT2025-10	20	25	06MA	10	8	19	2
A1MFT2520	25	20	06MA	18	6	27	3,3
A1MFT3030	30	30	08MA	23	8	37	4,7
A1MFT4030	40	30	08MA	23	8	59	10
A1MFT5030	50	30	10MA	28	10	95	13
A1MFT5035	50	35	10MA	28	10	95	13
A1MFT5050	50	50	10MA	28	10	80	9,4
A1MFT6035	60	35	10MA	30	10	137	27
A1MFT7550	75	50	12MA	37	12	224	45

**Caratteristiche**
**MATERIALE CORPO:** Mescola gomma NR/SBR

**DUREZZA STANDARD:** 45 shore A

**TOLLERANZA SULLA DUREZZA:** +/- 5 SH

**A RICHIESTA:** Differenti lunghezze della vite, inserto femmina passante

**PARTE METALLICA E/O FISSAGGIO:** Rondella zincata

**TIPO INSERTO STANDARD:** Vite zincata, inserto femmina cieco

**Product specificatio**
**MAIN PART MATERIAL:** NR/SBR rubber compound

**STANDARD HARDNESS:** 45 shore A

**HARDNESS TOLERANCE:** +/- 5 SH

**ON REQUEST:** Different screw lengths, threaded through-hole

**METALLIC PART:** Zinc plated washer

**STANDARD THREAD:** Zinc plated screw, threaded blind hole

Misure e durezza differenti producibili su richiesta, rivolgersi all'ufficio commerciale. La quota "E" ed "F" possono essere soggette a variazioni senza preavviso, ci riserviamo inoltre la facoltà di fornire antivibranti provvisti di inserto cieco o passante a seconda della disponibilità di parti metalliche.

Other sizes or hardness can be produced on demand, for information please contact our sales department. "E" and "F" dimensions can vary without giving notice. It is GeTech's discretion to supply antivibration mountings whit threaded blind hole or with through hole depending on the metallic parts available at the moment.

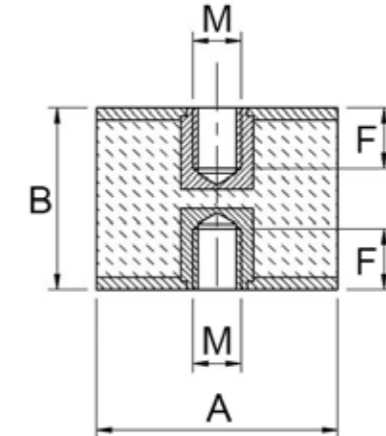
**FF**
**Antivibrante Cilindrico in Acciaio Zincato Femmina/Femmina**  
*Zinc Plated Double Female Cylindrical Mounting*

COD.	A	B	M	F	Carico max a Compres. Max Compression Load daN	Carico max a Taglio Max Shear Load daN
A1FF1515	15	15	04MA	4	15	2
A1FF2020	20	20	06MA	6	20	2
A1FF2025	20	25	06MA	6	18	2
A1FF2030	20	30	06MA	6	16	2
A1FF2520	25	20	06MA	6	45	5
A1FF2525	25	25	06MA	6	42	4
A1FF2530	25	30	06MA	6	35	3
A1FF3020	30	20	08MA	8	66	9
A1FF3030	30	30	08MA	8	61	8
A1FF3040	30	40	08MA	8	54	5
A1FF4030/10	40	30	10MA	10	98	15
A1FF4030/8	40	30	08MA	8	98	15
A1FF4035/8	40	35	08MA	8	108	13
A1FF4040/10	40	40	10MA	10	108	13
A1FF4040/8	40	40	08MA	8	108	13
A1FF5030	50	30	10MA	10	169	19
A1FF5040	50	40	10MA	10	144	17
A1FF5050	50	50	10MA	10	134	13
A1FF6030/10	60	30	10MA	10	210	30
A1FF6030/12	60	30	12MA	12	210	30
A1FF6040/12	60	40	12MA	12	210	30
A1FF6050/10	60	50	10MA	10	200	24
A1FF7530	75	30	12MA	12	390	90
A1FF7540	75	40	12MA	12	378	78
A1FF7550	75	50	12MA	12	373	68
A1FF10050	100	50	16MA	16	660	98
A1FF10055	100	55	16MA	16	636	78
A1FF10060	100	60	16MA	16	590	49

**Caratteristiche**
**MATERIALE CORPO:** Mescola Gomma NR/SBR

**DUREZZA STANDARD:** 60 shore A

**TOLLERANZA SULLA DUREZZA:** +/- 5 SH

**A RICHIESTA:** Inserto femmina passante

**PARTE METALLICA E/O FISSAGGIO:** Rondella zincata

**TIPO INSERTO STANDARD:** Inserto femmina cieco

**Product specificatio**
**MAIN PART MATERIAL:** NR/SBR rubber compound

**STANDARD HARDNESS:** 60 shore A

**HARDNESS TOLERANCE:** +/- 5 SH

**ON REQUEST:** Threaded through-hole

**METALLIC PART:** Zinc plated washer

**STANDARD THREAD:** Threaded blind hole

Misure e durezza differenti producibili su richiesta, rivolgersi all'ufficio commerciale.

Other sizes or hardness can be produced on demand, for information please contact our sales department.

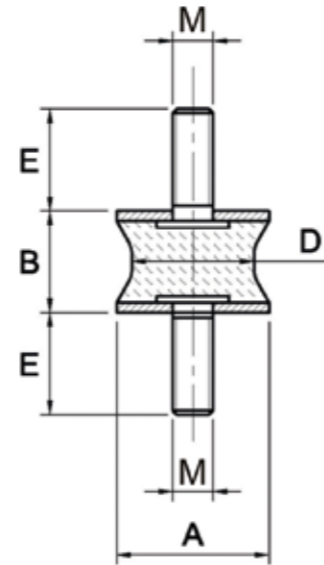
**MS**
**Antivibrante Sgolato Maschio/Maschio**  
*Sand-Glass Mounting Double Male*

COD.	A	B	M	D	E	Carico max a Compres. Max Compression Load daN	Carico max a Taglio Max Shear Load daN
A2MS12	12	15	04MA	7	10	3	0,8
A2MS25	25	20	06MA	10	18	50	3
A2MS30	30	20	08MA	20	20	60	10
A2MS40	40	30	08MA	19	20	80	6
A2MS40L	40	30	08MA	27	20	100	8

**Caratteristiche**
**MATERIALE CORPO:** Mescola gomma NR/SBR

**DUREZZA STANDARD:** 60 shore A

**TOLLERANZA SULLA DUREZZA:** +/- 5 SH

**A RICHIESTA:** Differenti lunghezze della vite

**PARTE METALLICA E/O FISSAGGIO:** Vite e rondella zincate

**TIPO INSERTO STANDARD:** Vite pressata sulla rondella

**Product specificatio**
**MAIN PART MATERIAL:** NR/SBR rubber compound

**STANDARD HARDNESS:** 60 shore A

**HARDNESS TOLERANCE:** +/- 5 SH

**ON REQUEST:** Different screw lengths

**METALLIC PART:** Zinc plated screw and washer

**STANDARD THREAD:** Screw pressed on the washer

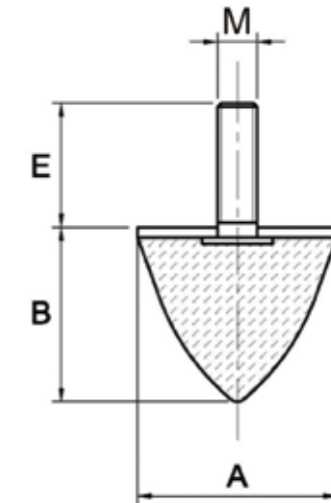
**CN**
**Antivibrante Conico**  
*Shock - Absorber*

COD.	A	B	M	E	Carico max a Compres. Max Compression Load daN
A2CN24	25	22	06MA	20	20
A2CN25	25	22	10MA	20	20
A2CN26	25	30	06MA	18	18
A2CN31	30	36	08MA	23	25
A2CN39	40	30	08MA	23	29
A2CN41	40	60	08MA	23	28
A2CN51	50	50	10MA	28	54
A2CN52	50	64	08MA	35	50
A2CN61	60	60	12MA	33	72
A2CN75	75	70	12MA	37	117
A2CN100	100	85	16MA	42	330

**Caratteristiche**
**MATERIALE CORPO:** Mescola gomma NR/SBR

**DUREZZA STANDARD:** 60 shore A

**TOLLERANZA SULLA DUREZZA:** +/- 5 SH

**A RICHIESTA:** Differenti lunghezze della vite

**PARTE METALLICA E/O FISSAGGIO:** Vite e rondella zincate

**TIPO INSERTO STANDARD:** Vite pressata sulla rondella

**Product specificatio**
**MAIN PART MATERIAL:** NR/SBR rubber compound

**STANDARD HARDNESS:** 60 shore A

**HARDNESS TOLERANCE:** +/- 5 SH

**ON REQUEST:** Different screw lengths

**METALLIC PART:** Zinc plated screw and washer

**STANDARD THREAD:** Screw pressed on the washer

**B**

**Barra Antivibrante**  
*Antivibration Bar*

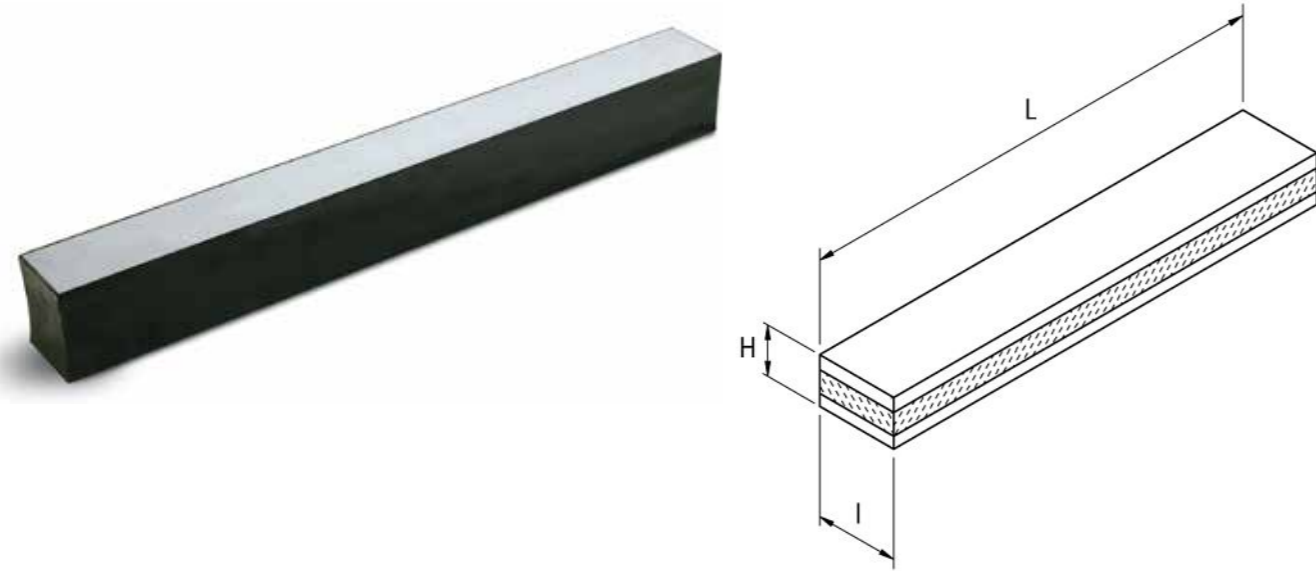

COD.	I	H	L	Spessore Ferri Thickness Metal Plates mm	Carico max a Compres. Max Compression Load daN
A2B50L	50	50	1000	10	14 / cm2
A2B60L	60	60	1000	10	14 / cm2
A2B80L	80	60	1000	10	14 / cm2
A2B100L	100	60	1000	10	14 / cm2

**Caratteristiche**

**MATERIALE CORPO:** Mescola gomma NR/SBR  
**DUREZZA STANDARD:** 60 shore A  
**TOLLERANZA SULLA DUREZZA:** +/- 5 SH  
**PARTE METALLICA E/O FISSAGGIO:** Fe 36 zincato

**Product specificatio**

**MAIN PART MATERIAL:** NR/SBR rubber compound  
**STANDARD HARDNESS:** 60 shore A  
**HARDNESS TOLERANCE:** +/- 5 SH  
**METALLIC PART:** Zinc plated iron

**SB**

**Supporto Antivibrante Cabina Conico**  
*Conical Support*

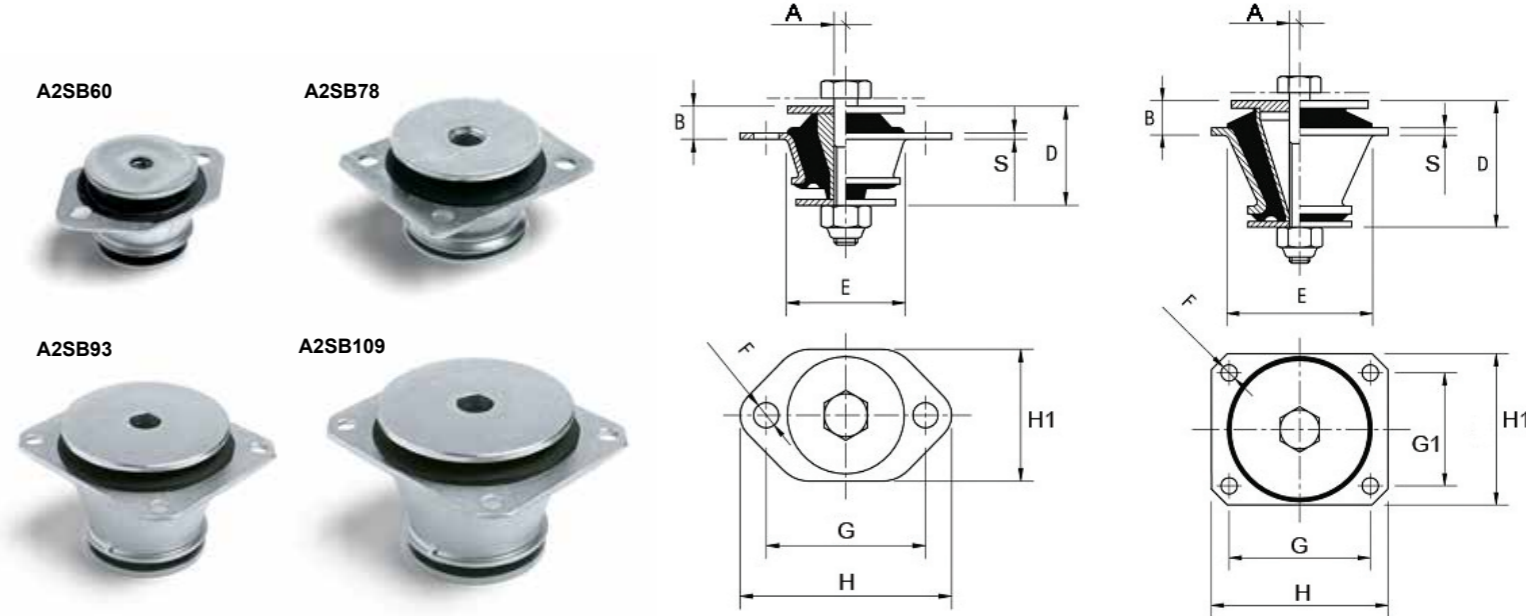

COD.	A	B	S	D	E	F	H1	H	G	G1	Carico max a Compres. Max Compression Load daN
A2SB60	12	16,5	2,5	51	57	11x14	68	106	80	nd	200
A2SB78	16	19,5	4	53	80	11	90	107	80	65	400
A2SB93	16	20	4	73	94,5	11	101	120	90	74	900
A2SB109	20	23	5	86	115	11	120	140	112	92	1600

**Caratteristiche**

**MATERIALE CORPO:** Mescola gomma NR/SBR  
**DUREZZA STANDARD:** 60 shore A  
**TOLLERANZA SULLA DUREZZA:** +/- 5 SH  
**A RICHIESTA:** Durezza 45 shore A  
**PARTE METALLICA E/O FISSAGGIO:** Acciaio zincato

**Product specificatio**

**MAIN PART MATERIAL:** NR/SBR rubber compound  
**STANDARD HARDNESS:** 60 shore A  
**HARDNESS TOLERANCE:** +/- 5 SH  
**ON REQUEST:** 45 shore A hardness  
**METALLIC PART:** Zinc plated steel

**SC**

Supporto Antivibrante a Campana con Foro Passante  
Bell Support with Through Hole

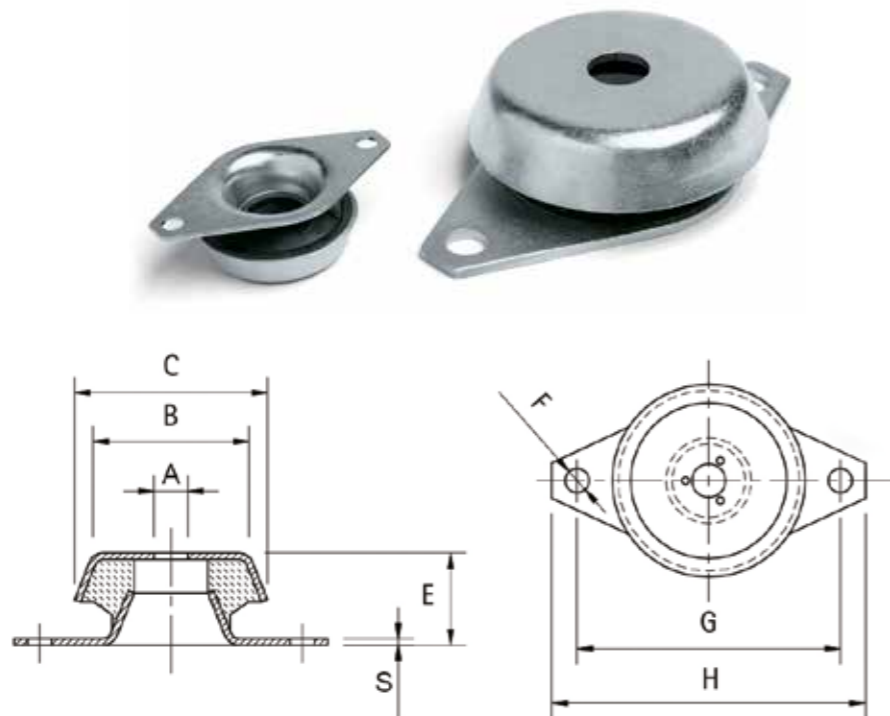

COD.	A	C	B	G	H	F	E	S	Durezza Hardness Shore A	Carico max Statico Max Load daN	Cedimento Deflectio mm
A2SC50	8	48	38	68	80	6	23	2	60	102	3,04
A2SC60	10	62	50	85	100	10	30	2	60	214	3,66
A2SC90	16	92	72	110	130	10	44	3	60	350	3,02
A2SC120	24	119	95	160	190	16	49	4	60	661	3,71
A2SC160	30	158	125	200	230	16	60	5	60	1211	3,36
A2SC50-45	8	48	38	68	80	6	23	2	45	96	3,18
A2SC60-45	10	62	50	85	100	10	30	2	45	192	5,03
A2SC90-45	16	92	72	110	130	10	44	3	45	341	5,05
A2SC120-45	24	119	95	160	190	16	49	4	45	641	4,92

**Caratteristiche**

**VERSIONE SUPPORTO:** Con foro passante  
**MATERIALE CORPO:** Mescola gomma NR/SBR  
**TOLLERANZA SULLA DUREZZA:** +/- 5 SH  
**PARTE METALLICA E/O FISSAGGIO:** Lamiera acciaio zincata

**Product specificatio**

**VERSION:** With through hole  
**MAIN PART MATERIAL:** NR/SBR rubber compound  
**HARDNESS TOLERANCE:** +/- 5 SH  
**METALLIC PART:** Zinc plated steel sheet

**SC/D**

Supporto Antivibrante a Campana con Dado  
Bell Support with Threaded Nut

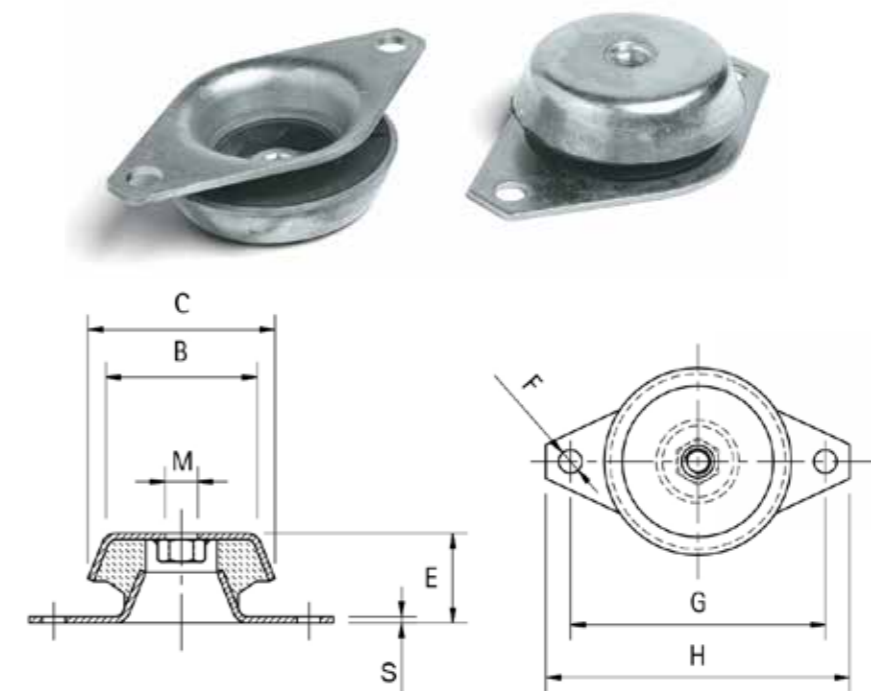

COD.	M	C	B	G	H	F	E	S	Durezza Hardness Shore A	Carico max Statico Max Load daN	Cedimento Deflectio mm
A2SC60/10	10MA	62	50	85	100	10	30	2	60	214	3,66
A2SC60/12	12MA	62	50	85	100	10	30	2	60	214	3,66
A2SC90/12	12MA	92	72	110	130	10	44	3	60	343	3,02
A2SC90/14	14MA	92	72	110	130	10	44	3	60	343	3,02
A2SC90/16	16MA	92	72	110	130	10	44	3	60	343	3,02
A2SC120/16	16MA	119	95	160	190	16	49	4	60	641	3,71
A2SC120/24	24MA	119	95	160	190	16	49	4	60	641	3,71
A2SC60/10-45	10MA	62	50	85	100	10	30	2	45	192	5,03
A2SC60/12-45	12MA	62	50	85	100	10	30	2	45	192	5,03
A2SC90/12-45	12MA	92	72	110	130	10	44	3	45	346	5,05
A2SC90/14-45	14MA	92	72	110	130	10	44	3	45	346	5,05

**Caratteristiche**

**VERSIONE SUPPORTO:** Con dado filettato saldat  
**MATERIALE CORPO:** Mescola gomma NR/SBR  
**TOLLERANZA SULLA DUREZZA:** +/- 5 SH  
**PARTE METALLICA E/O FISSAGGIO:** Lamiera acciaio zincata

**Product specificatio**

**VERSION:** With welded threaded nut  
**MAIN PART MATERIAL:** NR/SBR rubber compound  
**HARDNESS TOLERANCE:** +/- 5 SH  
**METALLIC PART:** Zinc plated steel sheet

**SCT**

Supporto Antivibrante a Campana con Antistrappo  
 Tear Resistant Bell Support

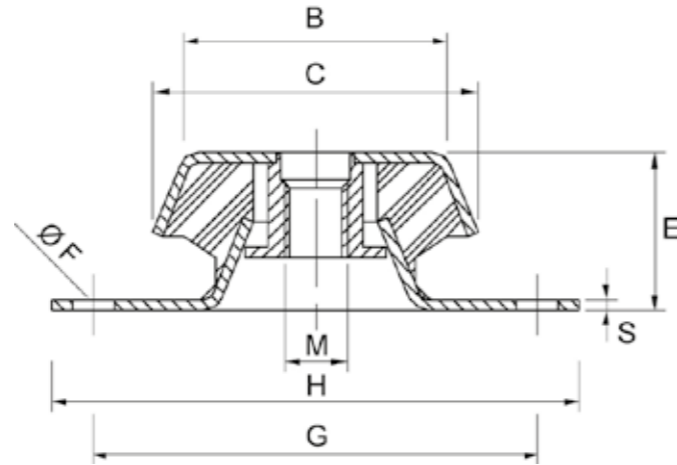

COD.	M	C	B	G	H	F	E	S	Durezza Hardness Shore A	Carico max Statico Max Load daN
A2SCT60/10	10MA	62	50	85	100	8	30	2	60	250
A2SCT90/12	12MA	92	72	110	130	10	44	3	60	360
A2SCT90/16	16MA	92	72	110	130	10	44	3	60	360
A2SCT120/16	16MA	119	95	160	190	16	49	4	60	650

**Caratteristiche**

**VERSIONE SUPPORTO:** Con antistrappo vulcanizzato e filettat

**MATERIALE CORPO:** Miscela gomma NBR

**TOLLERANZA SULLA DUREZZA:** +/- 5 SH

**PARTE METALLICA E/O FISSAGGIO:** Lamiera acciaio zincata

**Caratteristiche Specifiche:**

La Versione SCT, identica alla SC come dimensioni esterne, si caratterizza per la presenza di un tampone antistrappo all'interno della calotta (Vedi foto). Ciò impedisce nella maniera più assoluta il distacco della stessa dalla base, anche in presenza di forti strappi e vibrazioni, come ad esempio quelli generati dalla messa in moto iniziale di un potente motore a scoppio. La speciale miscela in NBR conferisce a questo antivibrante una grande resistenza all'olio ed un'ottima flessibilità trasversale

**Product specification**

**VERSION:** With vulcanized threaded shock-absorber

**MAIN PART MATERIAL:** NBR rubber compound

**HARDNESS TOLERANCE:** +/- 5 SH

**METALLIC PART:** Zinc plated steel sheet

**Specific Features**

The SCT model, which has the same external dimensions of the SC model, includes an antivibration pad with failsafe. This leads to a reliable machine fixing that prevents from detachment even in case of strong tearing and vibrations (for example when firing-up a powerful combustion engine). The NBR compound of the base offers optimal stability and high resistance to oils.

**SCQ**

Supporto Antivibrante a Campana a Base Quadra con Dado  
 Square Bell Support with Threaded Nut

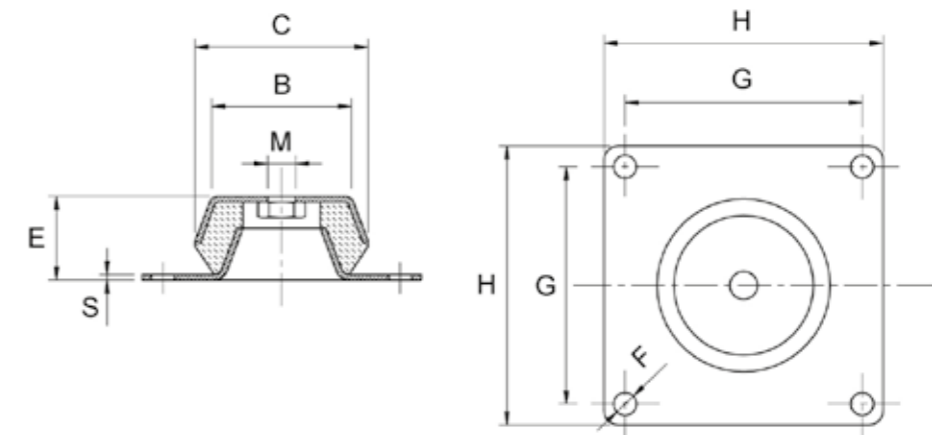

COD.	M	C	B	G	H	F	E	S	Durezza Hardness Shore A	Carico max Statico Max Load daN
A2SCQ150	16MA	150	110	132	168	13	51	4	55	500
A2SCQ150-70	16MA	150	110	132	168	13	51	4	70	600
A2SCQ177	20MA	175	125	150	180	13	63	4	60	850

**Caratteristiche**

**VERSIONE SUPPORTO:** Con dado filettato saldat

**MATERIALE CORPO:** Miscela gomma NR/SBR

**TOLLERANZA SULLA DUREZZA:** +/- 5 SH

**A RICHIESTA:** Durezza 45 shore A

**PARTE METALLICA E/O FISSAGGIO:** Lamiera acciaio zincata

**Product specification**

**VERSION:** With welded threaded nut

**MAIN PART MATERIAL:** NB/SBR rubber compound

**HARDNESS TOLERANCE:** +/- 5 SH

**ON REQUEST:** 45 shore A hardness

**METALLIC PART:** Zinc plated steel sheet



**SCQT**

Supporto Antivibrante a Campana a Base Quadra con Antistrappo  
Tear Resistant Square Bell Support

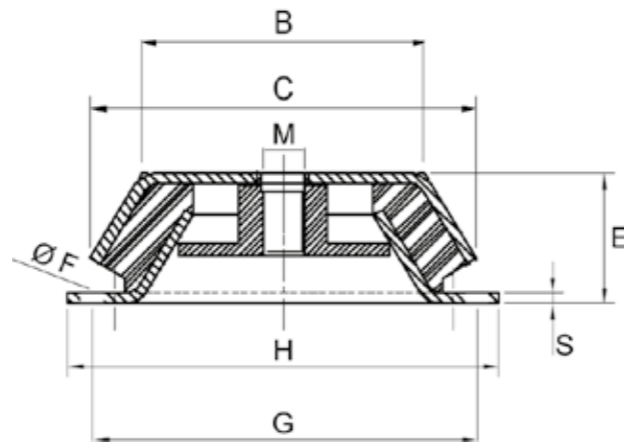

COD.	M	C	B	G	F	H	E	S	Durezza Hardness Shore A	Carico max Statico Max Load daN
A2SCQT150	16MA	150	110	132	13	168	51	4	55	500
A2SCQT177	20MA	175	125	150	13	180	63	4	55	850

**Caratteristiche**

**VERSIONE SUPPORTO:** Con antistrappo vulcanizzato e filettat

**MATERIALE CORPO:** Mescola gomma NBR

**TOLLERANZA SULLA DUREZZA:** +/- 5 SH

**A RICHIESTA:** Durezza 45 shore A

**PARTE METALLICA E/O FISSAGGIO:** Lamiera acciaio zincata

Caratteristiche Specifiche:

La versione SCQT, identica alla SCQ come dimensioni esterne, si caratterizza per la presenza di un tampone antistrappo all'interno della calotta (Vedi Foto). Ciò impedisce nella maniera più assoluta il distacco della stessa dalla base, anche in presenza di forti strappi e vibrazioni, come ad esempio quelli generati dalla messa in moto iniziale di un potente motore a scoppio. La speciale mescola in NBR conferisce a questo antivibrante una grande resistenza all'olio ed un'ottima flessibilità trasversale

**Product specification**

**VERSION:** With vulcanized threaded shock-absorber

**MAIN PART MATERIAL:** NBR rubber compound

**HARDNESS TOLERANCE:** +/- 5 SH

**ON REQUEST:** 45 shore A hardness

**METALLIC PART:** Zinc plated steel sheet

Specific Features

The SCQT model, which has the same external sizes of the SCQ model, includes an anti vibration pad with failsafe. This leads to a reliable machine fixing that prevents from detachment even in case of strong tearing and vibrations (for example when firing-up a powerful combustion engine). The NBR compound of the base offers optimal stability and high resistance to oils.

**SL**

Supporto Antivibrante "LONGLIFE"  
"Longlife" Antivibration Support

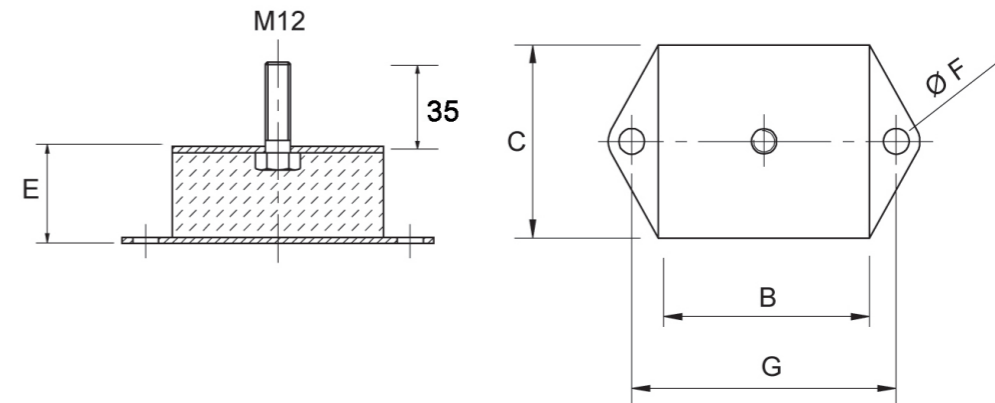

COD.	C	B	G	E	F	Carico max Statico Max Load daN
A2SL60	70	80	105	53	11	950

**Caratteristiche**

**MATERIALE CORPO:** Mescola gomma NR/SBR

**DUREZZA STANDARD:** 60 shore A

**TOLLERANZA SULLA DUREZZA:** +/- 5 SH

**A RICHIESTA:** 45 shore A

**PARTE METALLICA E/O FISSAGGIO:** Lamiera acciaio zincata

**TIPO INSERTO STANDARD:** Con perno filettato M 12X27

**Product specificatio**

**MAIN PART MATERIAL:** NBR rubber compound

**STANDARD HARDNESS:** 60 shore A

**HARDNESS TOLERANCE:** +/- 5 SH

**ON REQUEST:** 45 shore A hardness

**METALLIC PART:** Zinc plated steel sheet

**STANDARD THREAD:** With screw MA 12x27

**SF**

**SFF**

**Supporto Antivibrante Rettangolare Forato**  
*Rectangular Antivibration Support*

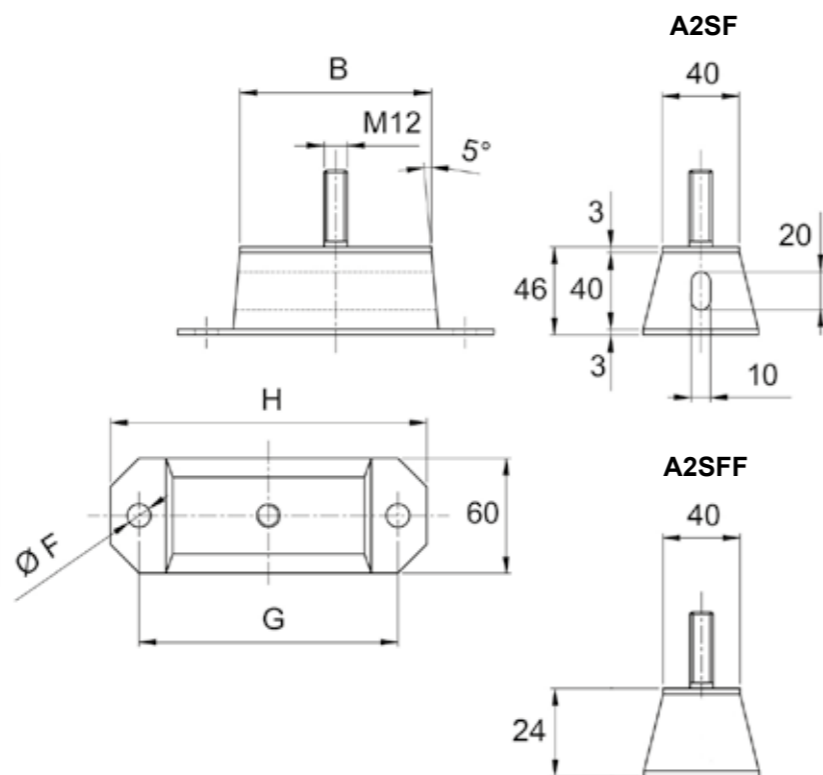

COD.	B	G	H	F	Carico max Statico Max Load daN
A2SF50	50	85	115	12,2	300
A2SF100	100	135	165	12,2	500
A2SFF100	100	135	165	12,2	500
A2SF150	150	185	215	12,2	750
A2SF200	200	235	265	12,2	1000

**Caratteristiche**

**MATERIALE CORPO:** Miscela gomma NR/SBR  
**DUREZZA STANDARD:** 60 shore A  
**TOLLERANZA SULLA DUREZZA:** +/- 5 SH  
**A RICHIESTA:** 45 shore A  
**PARTE METALLICA E/O FISSAGGIO:** Lamiera acciaio zincato  
**TIPO INSERTO STANDARD:** Con perno filettato M 12x37  
**ART. A2SFF100 con perno estraibile**

**Product specificatio**

**MAIN PART MATERIAL:** NBR rubber compound  
**STANDARD HARDNESS:** 60 shore A  
**HARDNESS TOLERANCE:** +/- 5 SH  
**ON REQUEST:** 45 shore A hardness  
**METALLIC PART:** Zinc plated steel sheet  
**STANDARD THREAD:** With screw MA 12x37  
**ART. A2SFF100 with extractable screw**

**PM**

**Piedino Antivibrante Maschio in Acciaio Zincato**  
*Zinc Plated Male Footing*

COD.	A	B	M	E	Carico max a Compres. Max Compression Load daN
A1PM1510	15	10	04MA	10	10
A1PM1515	15	15	04MA	14	10
A1PM1610	16	10	05MA	12	12
A1PM2008	20	8,5	06MA	10	18
A1PM2010	20	10	06MA	16	16
A1PM2015	20	15	06MA	16	18
A1PM2020	20	20	06MA	16	18
A1PM2025	20	25	06MA	16	18
A1PM2030	20	30	06MA	16	16
A1PM2515	25	15	06MA	18	29
A1PM2520/6	25	20	06MA	18	29
A1PM2520/8	25	20	08MA	20	29
A1PM2525	25	25	06MA	18	29
A1PM2530/6	25	30	06MA	18	29
A1PM2530/8	25	30	08MA	20	29
A1PM2530/8L	25	30	08MA	30	29
A1PM3010/6	30	10	06MA	18	42
A1PM3010	30	10	08MA	23	42
A1PM3010-40	30	10	08MA	40	42
A1PM3015	30	15	08MA	23	42
A1PM3020	30	20	08MA	23	42
A1PM3025	30	25	08MA	23	42
A1PM3030	30	30	08MA	23	38
A1PM3040	30	40	08MA	23	38
A1PM4020	40	20	08MA	23	57
A1PM4030/10	40	30	10MA	28	75
A1PM4030/8	40	30	08MA	23	75
A1PM4035/8	40	35	08MA	23	75
A1PM4040/10	40	40	10MA	28	75
A1PM4040/8	40	40	08MA	23	75
A1PM5020	50	20	10MA	28	117
A1PM5030	50	30	10MA	28	117
A1PM5040	50	40	10MA	28	117
A1PM5045	50	45	10MA	28	117
A1PM5050	50	50	10MA	28	117
A1PM6020/12	60	20	12MA	37	169
A1PM6030/12	60	30	12MA	37	169
A1PM6040/12	60	40	12MA	37	169
A1PM6050/10	60	50	10MA	37	169
A1PM6050/12	60	50	12MA	37	169
A1PM7525	75	25	12MA	37	265
A1PM7540	75	40	12MA	37	265
A1PM7550	75	50	12MA	37	265
A1PM10040	100	40	16MA	42	471
A1PM10050	100	50	16MA	42	471
A1PM10080	100	80	16MA	42	380

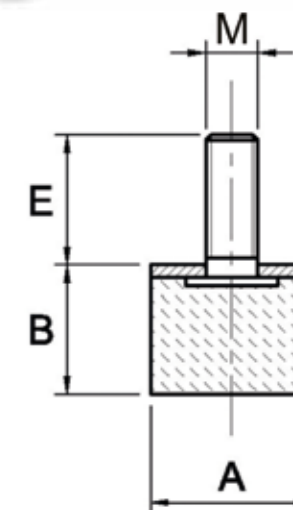

**Caratteristiche**

**MATERIALE CORPO:** Miscela gomma NR/SBR  
**DUREZZA STANDARD:** 60 shore A  
**TOLLERANZA SULLA DUREZZA:** +/- 5 SH  
**A RICHIESTA:** Differenti lunghezze della vite  
**PARTE METALLICA E/O FISSAGGIO:** Vite e rondella zincate  
**TIPO INSERTO STANDARD:** Vite pressata sulla rondella

**Product specification**

**MAIN PART MATERIAL:** NR/SBR rubber compound  
**STANDARD HARDNESS:** 60 shore A  
**HARDNESS TOLERANCE:** +/- 5 SH  
**ON REQUEST:** Different screw lengths  
**METALLIC PART:** Zinc plated screw and washer  
**STANDARD THREAD:** Screw pressed on the washer

Misure e durezze differenti producibili su richiesta, rivolgersi all'ufficio commerciale.

Other sizes or hardness can be produced on demand, for information please contact our sales department.

**PMT**
**Piedino Antivibrante Maschio in Acciaio Zincato (Gomma Tenera)**  
*Zinc Plated Male Footing (Soft Type)*

COD.	A	B	M	E	Carico max a Compres. Max Compression Load daN
A1PMT3020	30	20	08MA	20	30
A1PMT3030	30	30	08MA	20	40
A1PMT4030	40	30	08MA	23	55
A1PMT4040	40	40	08MA	23	55
A1PMT5040	50	40	10MA	28	85

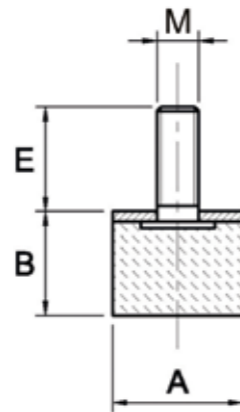
**Caratteristiche**

**MATERIALE CORPO:**  
Mescola gomma NR/SBR  
**DUREZZA STANDARD:**  
45 shore A  
**TOLLERANZA SULLA DUREZZA:**  
+/- 5 SH  
**A RICHIESTA:**  
Differenti lunghezze della Vite  
**PARTE METALLICA E/O FISSAGGIO:**  
Vite e rondella zincate  
**TIPO INSERTO STANDARD:**  
Vite pressata sulla rondella

**Product specificatio**

**MAIN PART MATERIAL:**  
NR/SBR rubber compound  
**STANDARD HARDNESS:**  
45 shore A  
**HARDNESS TOLERANCE:**  
+/- 5 SH  
**ON REQUEST:**  
Different screw lengths  
**METALLIC PART:**  
Zinc plated screw and washer  
**STANDARD THREAD:**  
Screw pressed on the washer

**PMX**
**Piedino Antivibrante Maschio in Acciaio Inox AISI 304**  
*AISI 304 Stainless Steel Male Footing*
**INOX**  
Stainless  
Steel

COD.	A	B	M	E	Carico max a Compres. Max Compression Load daN
A1PMX1515	15	15	04MA	14	15
A1PMX2015	20	15	06MA	16	34
A1PMX2520/6	25	20	06MA	18	45
A1PMX3030	30	30	08MA	20	61
A1PMX4030/8	40	30	08MA	23	98

Misure e durezze differenti producibili su richiesta, rivolgersi all'ufficio commerciale.  
*Other sizes or hardness can be produced on demand, for information please contact our sales department.*

**Caratteristiche**

**MATERIALE CORPO:**  
Mescola gomma NR/SBR  
**DUREZZA STANDARD:**  
60 shore A  
**TOLLERANZA SULLA DUREZZA:**  
+/- 5 SH  
**A RICHIESTA:**  
Differenti lunghezze della vite  
**PARTE METALLICA E/O FISSAGGIO:**  
Vite e rondella inox AISI 304  
**TIPO INSERTO STANDARD:**  
Vite pressata sulla rondella

**Product specificatio**

**MAIN PART MATERIAL:**  
NR/SBR rubber compound  
**STANDARD HARDNESS:**  
60 shore A  
**HARDNESS TOLERANCE:**  
+/- 5 SH  
**ON REQUEST:**  
Different screw lengths  
**METALLIC PART:**  
Stainless steel screw and washer AISI 304  
**STANDARD THREAD:**  
Screw pressed on the washer

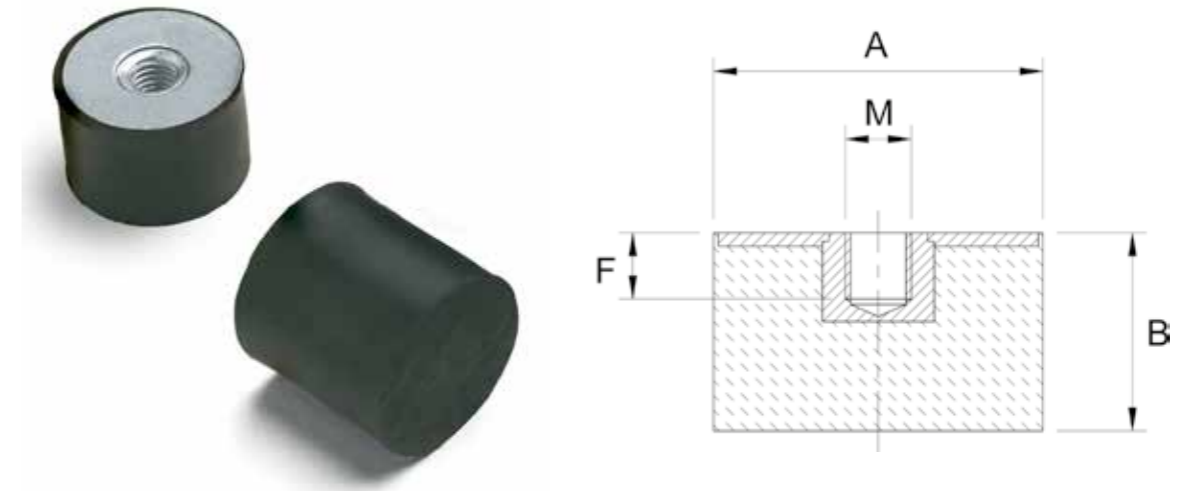
**PF**
**Piedino Antivibrante Femmina in Acciaio Zincato**  
*Zinc Plated Female Footing*

COD.	A	B	M	F	Carico max a Compres. Max Compression Load daN
A1PF2515	25	15	06MA	6	29
A1PF2518	25	18	06MA	9	29
A1PF2520	25	20	06MA	6	29
A1PF3020	30	20	08MA	8	42
A1PF3030	30	30	08MA	8	38
A1PF4030	40	30	08MA	8	75
A1PF5020	50	20	10MA	10	117
A1PF5030	50	30	10MA	9	117
A1PF6030	60	30	12MA	10	169
A1PF7525	75	25	12MA	12	265
A1PF7550	75	50	12MA	12	265

**Caratteristiche**

**MATERIALE CORPO:** Mescola gomma NR/SBR  
**DUREZZA STANDARD:** 60 shore A  
**TOLLERANZA SULLA DUREZZA:** +/- 5 SH  
**A RICHIESTA:** Altre durezze  
**PARTE METALLICA E/O FISSAGGIO:** Rondella sabbiata e zincata  
**TIPO INSERTO STANDARD:** Inserto femmina cieco

**Product specificatio**

**MAIN PART MATERIAL:** NR/SBR rubber compound  
**STANDARD HARDNESS:** 60 shore A  
**HARDNESS TOLERANCE:** +/- 5 SH  
**ON REQUEST:** Other hardnesses  
**METALLIC PART:** Zinc plated sandblasted washer  
**STANDARD THREAD:** Threaded blind hole

Misure e durezze differenti producibili su richiesta, rivolgersi all'ufficio commerciale.  
*Other sizes or hardness can be produced on demand, for information please contact our sales department.*

**CQ**

**Supporto Antivibrante Base Quadrata**  
**Square Base Support**

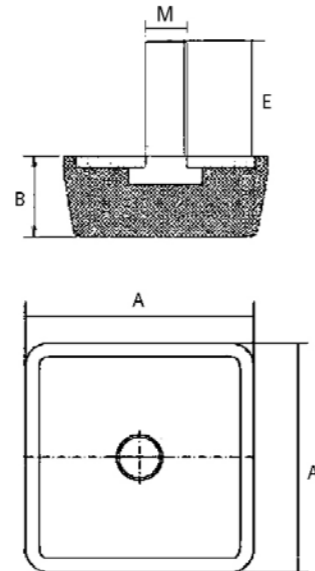

COD.	A	M	E	B	Carico max Statico Max Load daN
A2CQ80	80	10MA	27	30	450
A2CQ120	120	12MA	37	30	900

**Caratteristiche**

**MATERIALE CORPO:** Mescola gomma NR/SBR  
**DUREZZA STANDARD:** 70 shore A  
**TOLLERANZA SULLA DUREZZA:** +/- 5 SH  
**A RICHIESTA:** Durezza 45 shore A  
**PARTE METALLICA E/O FISSAGGIO:** Lamiera acciaio zincata

**Product specificatio**

**MAIN PART MATERIAL:** NR/SBR rubber compound  
**STANDARD HARDNESS:** 70 shore A  
**HARDNESS TOLERANCE:** +/- 5 SH  
**ON REQUEST:** 45 shore A hardness  
**METALLIC PART:** Zinc plated steel sheet

**TE**

**Piede Antivibrante "EXPORT" < 1000 kg**  
**"EXPORT" Antivibration Mount < 1000 kg**

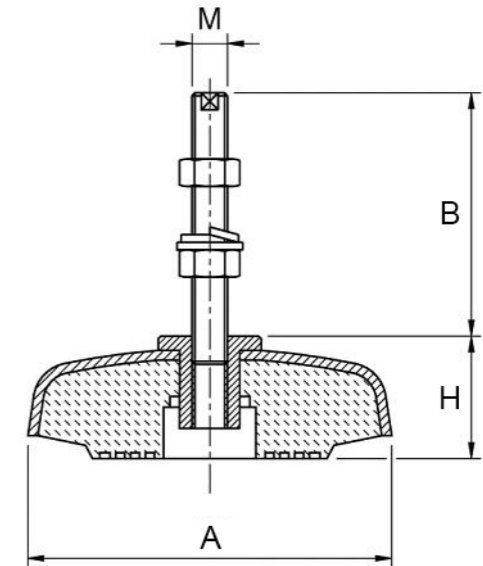

COD.	A	M	B	H	Chiave Spanner	Carico max Statico Max Load daN	
A4TE80	80	12MA	65	29	8	400	4
A4TE110	110	14MA	110	34	10	700	4
A4TE140	140	16MA	110	45	12	1000	4

**Caratteristiche**

**MATERIALE BASE:** Acciaio zincato  
**TIPO BASE:** Antivibrante  
**CORREDO BASE:** Suola in NBR vulcanizzata  
**MATERIALE STELO:** Acciaio zincato  
**TIPO STELO:** Barra filettata fresata in test  
**CORREDO STELO:** 2 dadi + 2 rondelle  
**PRESENTAZIONE PRODOTTO:** Stelo e base forniti smontati

**Product specificatio**

**BASE MATERIAL:** Zinc plated steel  
**BASE TYPE:** Antivibration  
**BASE OUTFIT:** NBR vulcanized plate  
**SPINDLE MATERIAL:** Zinc plated steel  
**SPINDLE TYPE:** Square headed threaded stud  
**SPINDLE OUTFIT:** 2 nuts + 2 washers  
**PRODUCT PRESENTATION:** Base and spindle not assembled

**TH**

Piede Antivibrante con Stelo Fisso < 3000 kg  
Antivibration Mount with Fixed Spindle < 3000 kg

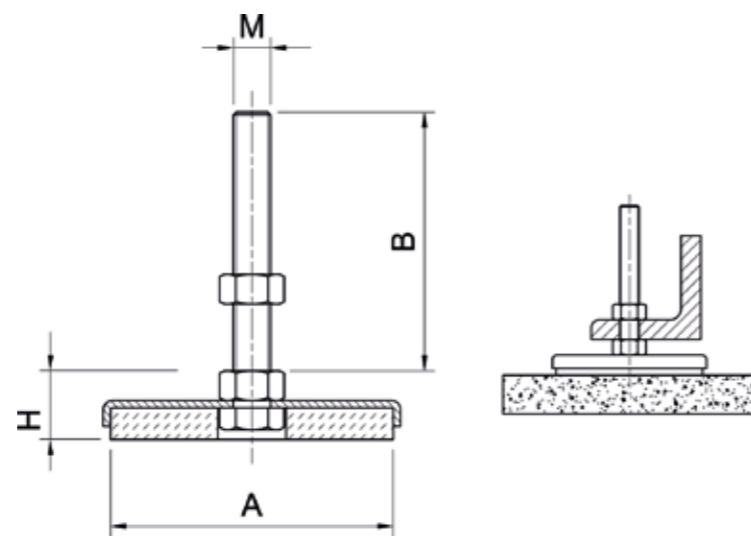

COD.	A	M	B	H	Carico max Statico Max Load daN	
A4TH400	40	10MA	50	25	600	4
A4TH500	50	12MA	75	27	700	4
A4TH600	80	12MA	100	31	800	4
A4TH1200	120	16MA	100	35	1000	4
A4TH3000	160	20MA	150	36	2000	4

**Caratteristiche**

**MATERIALE BASE:** Acciaio zincato  
**TIPO BASE:** Antivibrante  
**CORREDO BASE:** Suola in NBR 80 shore  
**MATERIALE STELO:** Acciaio zincato  
**TIPO STELO:** Fisso  
**CORREDO STELO:** Dado  
**PRESENTAZIONE PRODOTTO:** Stelo fornito già assemblato alla base

**Product specificatio**

**BASE MATERIAL:** Zinc plated steel  
**BASE TYPE:** Antivibration  
**BASE OUTFIT:** Plate NBR 80 shore  
**SPINDLE MATERIAL:** Zinc plated steel  
**SPINDLE TYPE:** Fixed  
**SPINDLE OUTFIT:** Nut  
**PRODUCT PRESENTATION:** Spindle assembled to the base

**ARTICOLO FUORI PRODUZIONE  
SOSTITUITO DA ART. THO  
DISCONTINUED PRODUCT  
REPLACE BY THO**

**THO**

Piede Antivibrante con Stelo Girevole "SHINE" < 3000 kg  
"SHINE" Antivibration Mount with Revolving Spindle < 3000 kg

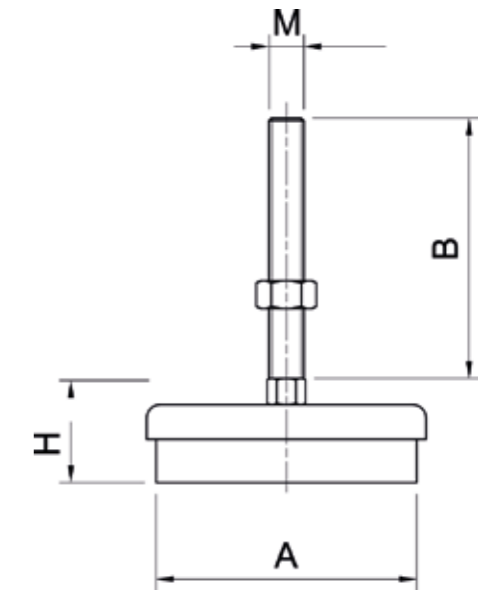

COD.	A	M	B	H	Carico max Statico Max Load daN	
A4THO400	40	10MA	49	34	600	4
A4THO600	80	12MA	100	44	800	4
A4THO1200	120	16MA	100	48	1000	4
A4THO3000	160	20MA	150	63	2000	4
A4THO4000	200	20MA	150	63	3000	4

**Caratteristiche**

**MATERIALE BASE:** Acciaio zincato  
**TIPO BASE:** Antivibrante  
**CORREDO BASE:** Suola in NBR 70 shore  
**MATERIALE STELO:** Acciaio zincato  
**TIPO STELO:** Girevole  
**CORREDO STELO:** Dado  
**PRESENTAZIONE PRODOTTO:** Stelo fornito già assemblato alla base

**Product specificatio**

**BASE MATERIAL:** Zinc plated steel  
**BASE TYPE:** Antivibration  
**BASE OUTFIT:** NBR 70 shore plate  
**SPINDLE MATERIAL:** Zinc plated steel  
**SPINDLE TYPE:** Revolving  
**SPINDLE OUTFIT:** Nut  
**PRODUCT PRESENTATION:** Spindle assembled to the base

**TK**

Zoccolo Antivibrante a Piattello < 4000 kg  
Leveling Mount < 4000 kg

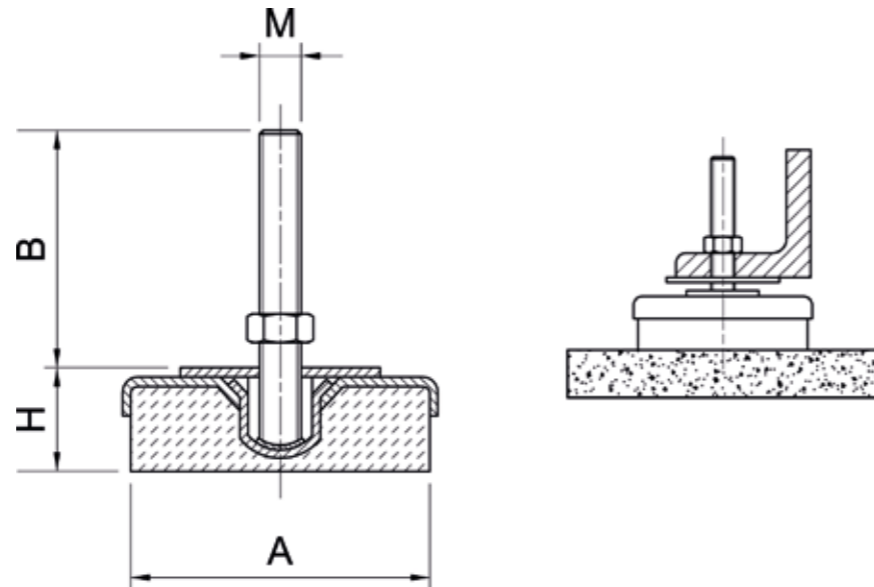

COD.	A	M	B	H	Chiave Spanner	Carico max Statico Max Load daN	
A4TK80	80	M12x1,25	100	45	12	700	4
A4TK120	120	M16x1,50	120	45	15	1000	4
A4TK160	160	M20x1,50	150	55	15	1500	4
A4TK200	200	M20x2,50	160	55	25	4000	4

**Caratteristiche**

**MATERIALE BASE:** Acciaio zincato  
**TIPO BASE:** Antivibrante regolabile in altezza  
**CORREDO BASE:** Suola in NBR 80 shore  
**MATERIALE STELO:** Acciaio zincato  
**TIPO STELO:** Barra filettata a passo fine fresata in testa (escluso art A4TK200)  
**CORREDO STELO:** 1 dado + 1 rondella  
**PRESENTAZIONE PRODOTTO:** Stelo e base forniti smontati

**Product specificatio**

**BASE MATERIAL:** Zinc plated steel  
**BASE TYPE:** Antivibration height adjustable  
**BASE OUTFIT:** NBR 80 shore plate  
**SPINDLE MATERIAL:** Zinc plated steel  
**SPINDLE TYPE:** Fine threaded square headed bolt (excluded art. A4TK200)  
**SPINDLE OUTFIT:** 1 nut + 1 washer  
**PRODUCT PRESENTATION:** Base and spindle not assembled

**TN**

**TNX**

Piede Antivibrante Orientabile con base in Acciaio Nichelato < 5800 kg  
Antivibration Mount with Nickel plated base < 5800 kg

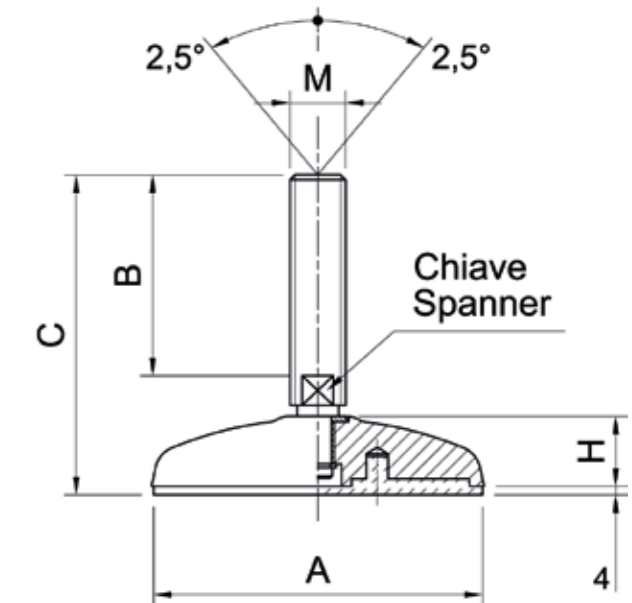

COD.	A	M	B	C	H	Chiave Spanner	Carico max Max Load daN	Stelo Stud	
A4TN16058	124	16MA	58	104	26	13	5500	Z	8
A4TNX16058	124	16MA	58	104	26	13	5500	X	8
A4TN16119	124	16MA	119	165	26	13	5500	Z	8
A4TNX16119	124	16MA	119	165	26	13	5500	X	8
A4TN16145	124	16MA	145	191	26	13	5500	Z	8
A4TNX16145	124	16MA	145	191	26	13	5500	X	8
A4TN16201	124	16MA	201	247	26	13	5500	Z	8
A4TNX16201	124	16MA	201	247	26	13	5500	X	8
A4TN18157	124	18MA	157	203	26	15	5500	Z	8
A4TNX18157	124	18MA	157	203	26	15	5500	X	8
A4TN20107	124	20MA	107	156	26	17	5600	Z	8
A4TNX20107	124	20MA	107	156	26	17	5600	X	8
A4TN20135	124	20MA	135	184	26	17	5600	Z	8
A4TNX20135	124	20MA	135	184	26	17	5600	X	8
A4TN20157	124	20MA	157	206	26	17	5600	Z	8
A4TNX20157	124	20MA	157	206	26	17	5600	X	8
A4TN20190	124	20MA	190	239	26	17	5600	Z	8
A4TNX20190	124	20MA	190	239	26	17	5600	X	8
A4TN20238	124	20MA	238	287	26	17	5600	Z	8
A4TNX20238	124	20MA	238	287	26	17	5600	X	8
A4TN24090	124	24MA	90	142	26	19	5700	Z	8
A4TNX24090	124	24MA	90	142	26	19	5700	X	8
A4TN24127	124	24MA	127	179	26	19	5700	Z	8
A4TNX24127	124	24MA	127	179	26	19	5700	X	8
A4TN24162	124	24MA	162	214	26	19	5700	Z	8
A4TNX24162	124	24MA	162	214	26	19	5700	X	8
A4TN24202	124	24MA	202	254	26	19	5700	Z	8
A4TNX24202	124	24MA	202	254	26	19	5700	X	8
A4TN30125	124	30MA	125	177	26	24	5800	Z	8
A4TNX30125	124	30MA	125	177	26	24	5800	X	8
A4TN30185	124	30MA	185	237	26	24	5800	Z	8
A4TNX30185	124	30MA	185	237	26	24	5800	X	8

**Caratteristiche**

**MATERIALE BASE:** Acciaio nichelato  
**MATERIALE STELO:** Z = Zincato  
 X= Acciaio inox AISI 304  
 Fornito completo di antivibrante colore nero in PVC morbido 68 shore  
**PRESENTAZIONE PRODOTTO:** Stelo fornito già assemblato alla base

**Product specification**

**BASE MATERIAL:** Nickel plated steel  
**STUD MATERIAL:** Z = Zinc plated  
 X= Stainless steel AISI 304  
 The feet are completed with anti-slip pad made in soft PVC 68 shore black colour.  
**PRODUCT PRESENTATION:** Spindle assembled to te base